

4-M10深18 (PCD75, 等分)
4-M10 depth 18 (PCD75, equal)

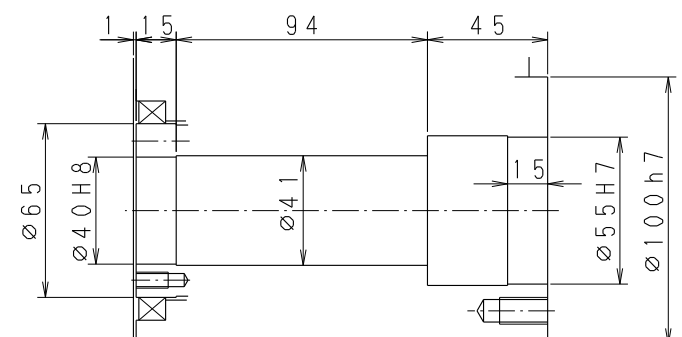

主軸断面図
Sectional view of turntable
(S=1/2)
(S=1/2)

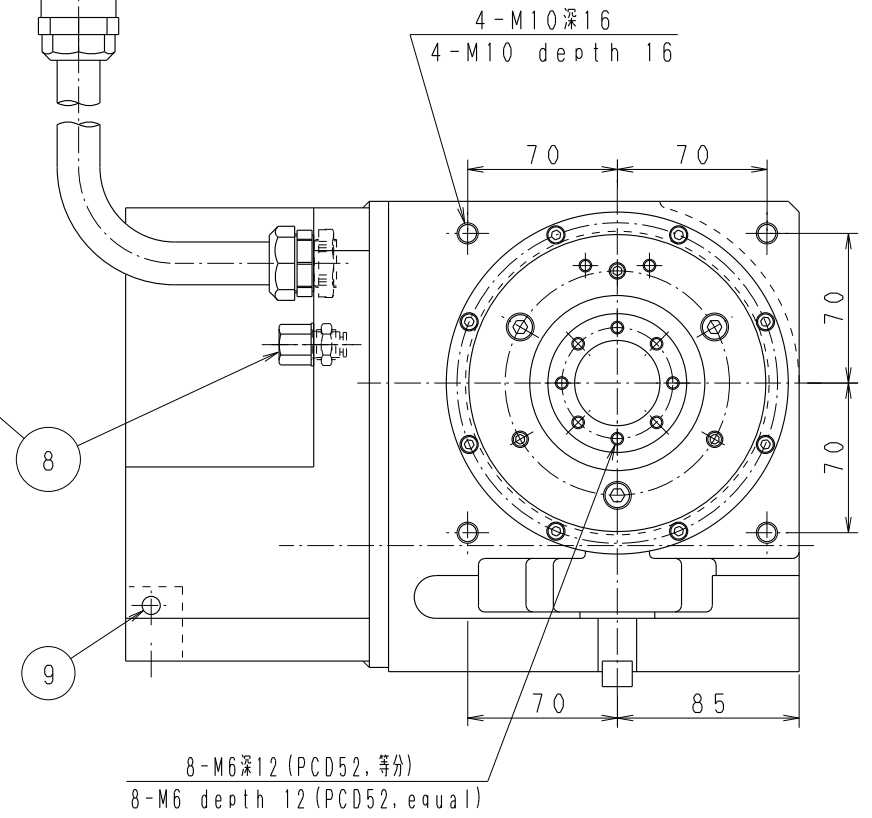
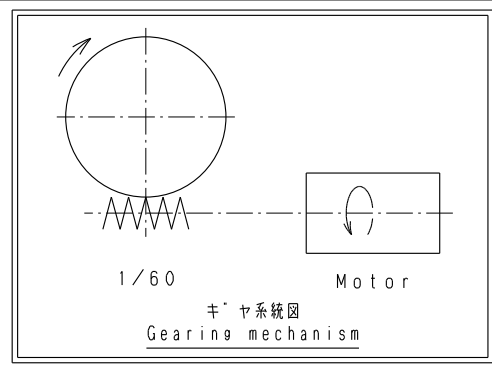
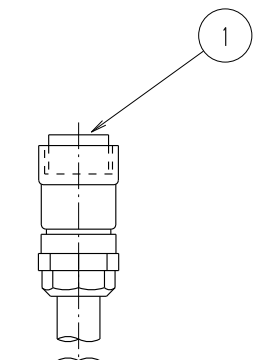
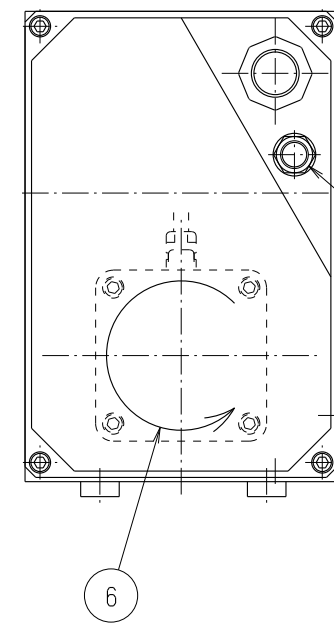
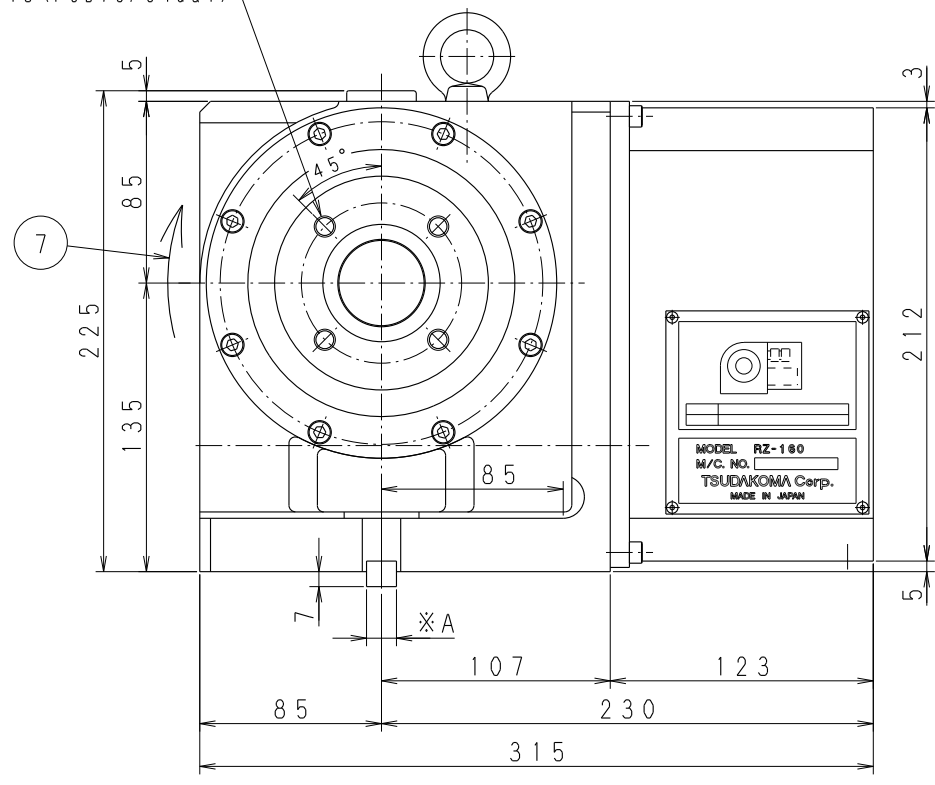
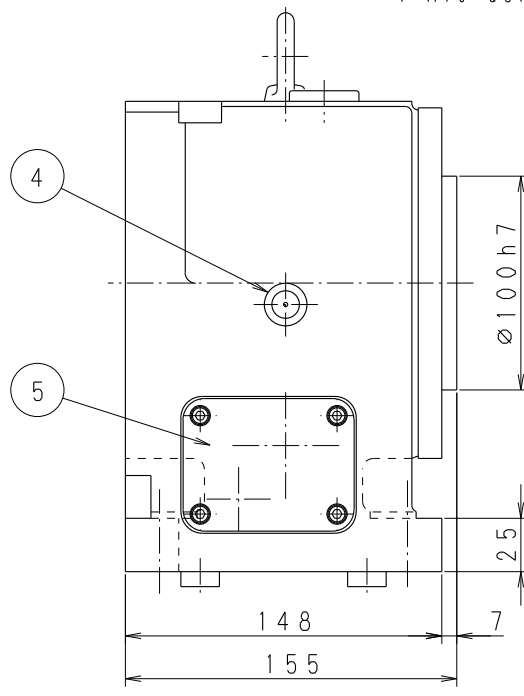
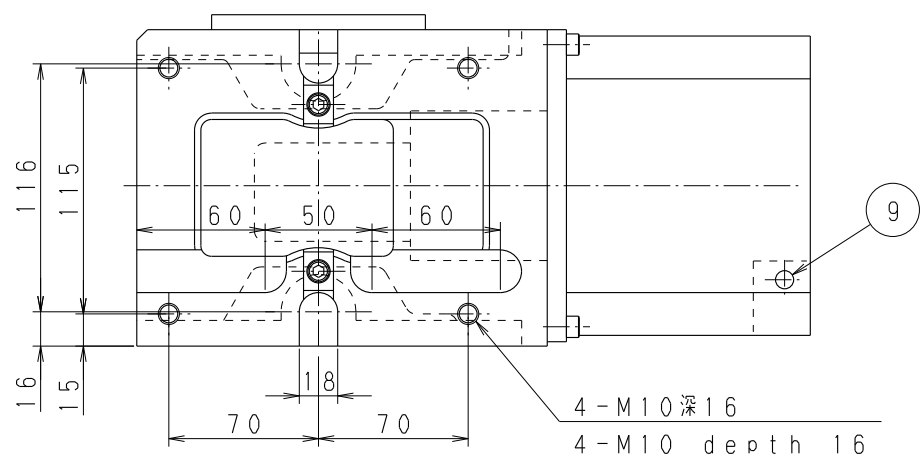

適用モータ APPLICABLE MOTOR	
モータ Motor	ターンテーブル許容最高回転数 Max. allowable turntable rotation speed
TPC-Jr-G2	33.3 min ⁻¹ (Motor 2000min ⁻¹)

指示箇所説明	NAME OF PART
1 リセプタクル MS3106B (動力, 検出器用) Receptacle MS3106B (Power, Signal)	7 ターンテーブル原点復帰回転方向 Turntable rotating direction at zero return
2	8 ターンテーブルクランプ及エアバース用 空圧投入口: PT1/4 (0.49MPa) Pneumatic feed port for turntable clamp operation and air purging PT1/4 (0.49MPa)
3 潤滑油注油口 Lubricant feed port	9 排出口 Exhaust port
4 オイルゲージ Oil level gauge	
5 潤滑油排油口 Lubricant drain port	
6 モータ原点復帰回転方向 Motor rotating direction at zero return	

仕様 SPECIFICATION	
モータ軸換算イナーシャ Motor shaft conversion inertia	1.86 × 10 ⁻⁴ kg · m ²
許容ワークイナーシャ Allowable work inertia	0.48 kg · m ²
クランプ力 Clamping force	157 N · m (Pressure 0.49MPa)
ホイール許容トルク Allowable wheel torque	147 N · m
積載質量 Load capacity	150 kg 75 kg
製品質量 Mass of rotary table	40 kg

* ガイドブロックA寸法はT12~T18まで対応可。

承認	訂正記号	年月日	訂正事項	訂正者
A x 1	02.01.06	MC/No 誤記訂正	末尾B付へ	桐木

名称	TITLE RZ-160	減速比	REDUCTION RATIO 1/60	クランプ	CLAMP Pneumatic
製図	DRAWN BY M. Kiriki	尺度	SCALE 1/2.5	単位	UNIT MM
承認	APPROVED BY	検図	CHECKED BY	日付	DATE Apr. 26, 19
				図番	DRAWING NO. TTS-021-M01B

1MPa=10.2kgf/cm² 1N=0.102kgf 1Kg·m²=10.2kgf·cm·sec² (1N·m·sec²=1kg·m²)