

General-purpose clammer

# V-clamp system



TSUDAKOMA TECHNO SUPPORT Corp.



## V-clamp

brother

# SPEEDIO R650X2

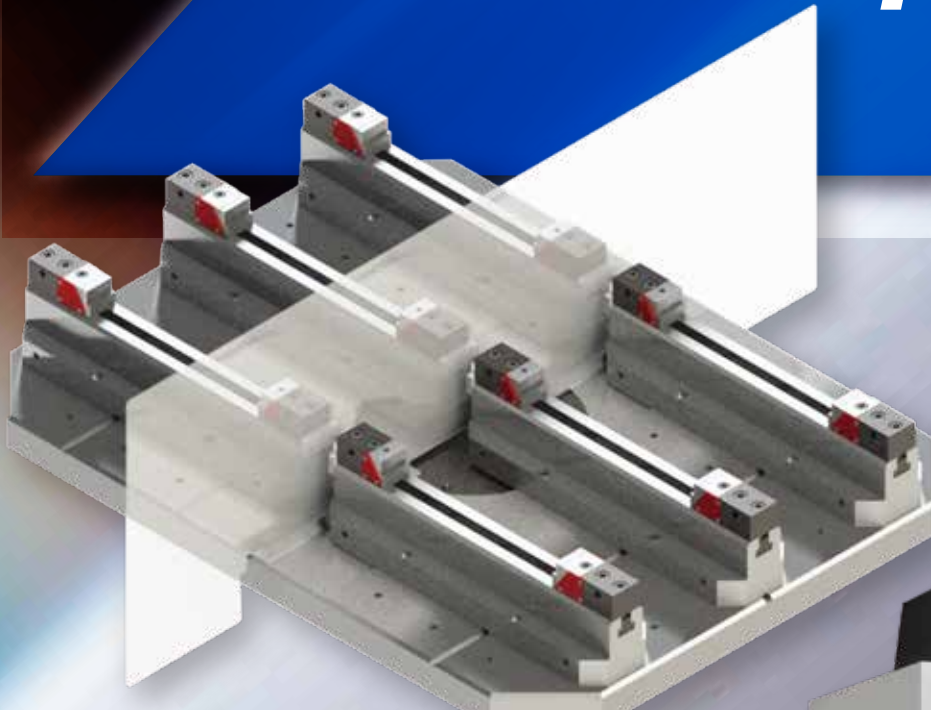

Machining area can be utilized to the utmost limit.

Easy setup on the machine.  
No worries about interference in the machine.



### Contact

DREAM NAVIGATOR  
SINCE 1909  
TSUDAKOMA

TSUDAKOMA Corp. Group company

**TSUDAKOMA TECHNO SUPPORT Corp.**

100 Awada 5-chome, Nonoichi, Ishikawa, 921-8529, JAPAN  
Phone:(076)294-5180, FAX(076)294-5156  
[www.tts-tsudakoma.co.jp](http://www.tts-tsudakoma.co.jp)



# Installation layout

## VCP-50F Clamp System + R650X2

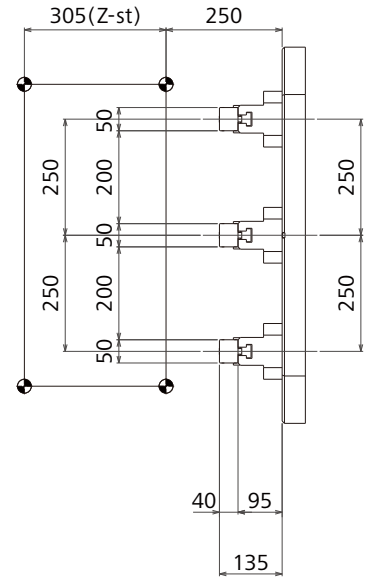
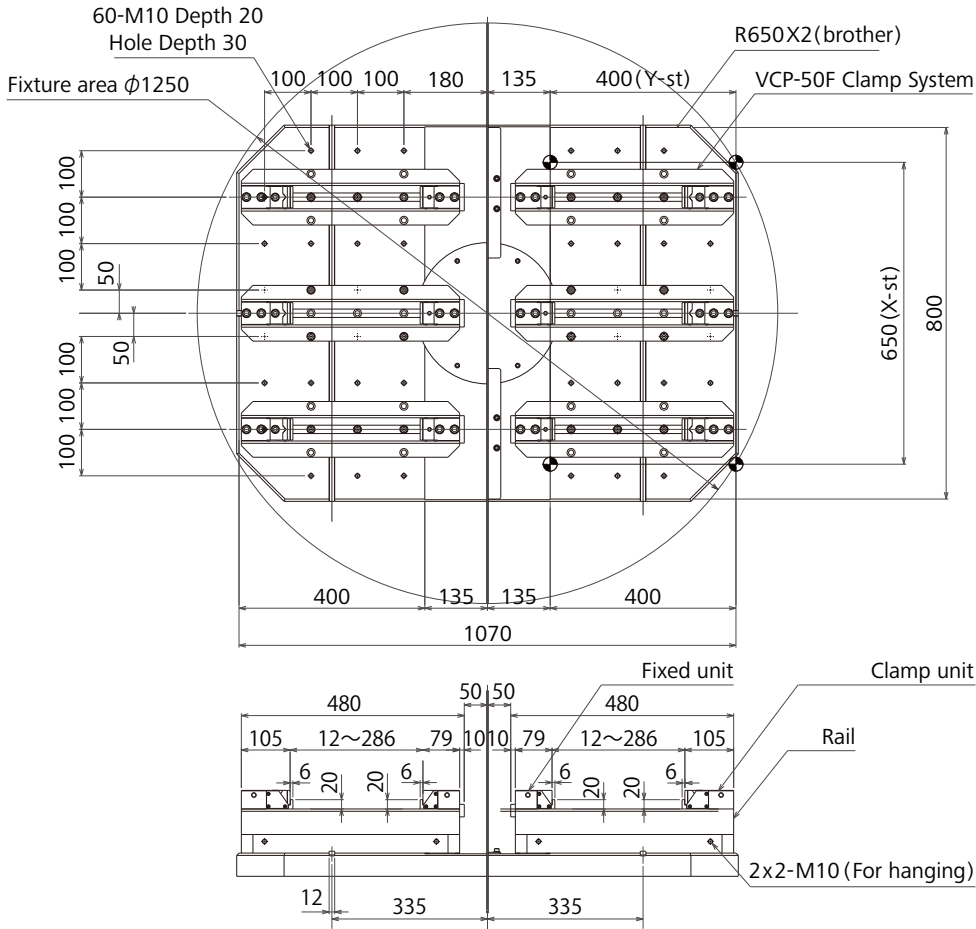

- ※ R650 Allowable weight: One pallet 200kg
- ※ Weight of clamp unit (included rail): 30kg/set

## VCP-80F Clamp System + R650X2

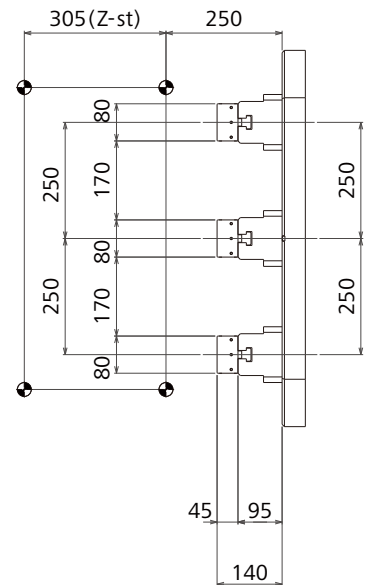
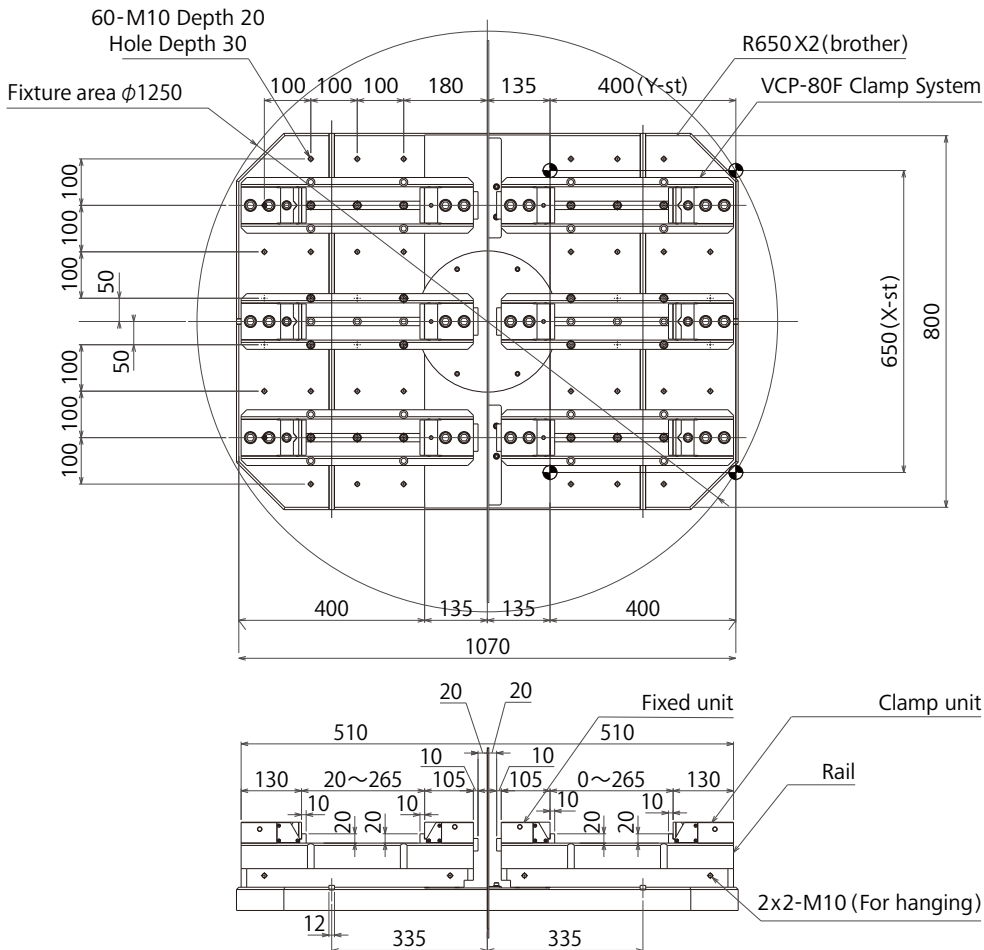

- ※ R650 Allowable weight: One pallet 200Kg
- ※ Weight of clamp unit (included rail): 42Kg/set