

通用夹具精密夹钳

# V-clamp System



TSUDAKOMA TECHNO SUPPORT Corp.



## V-clamp

brother

# SPEEDIO R650X2

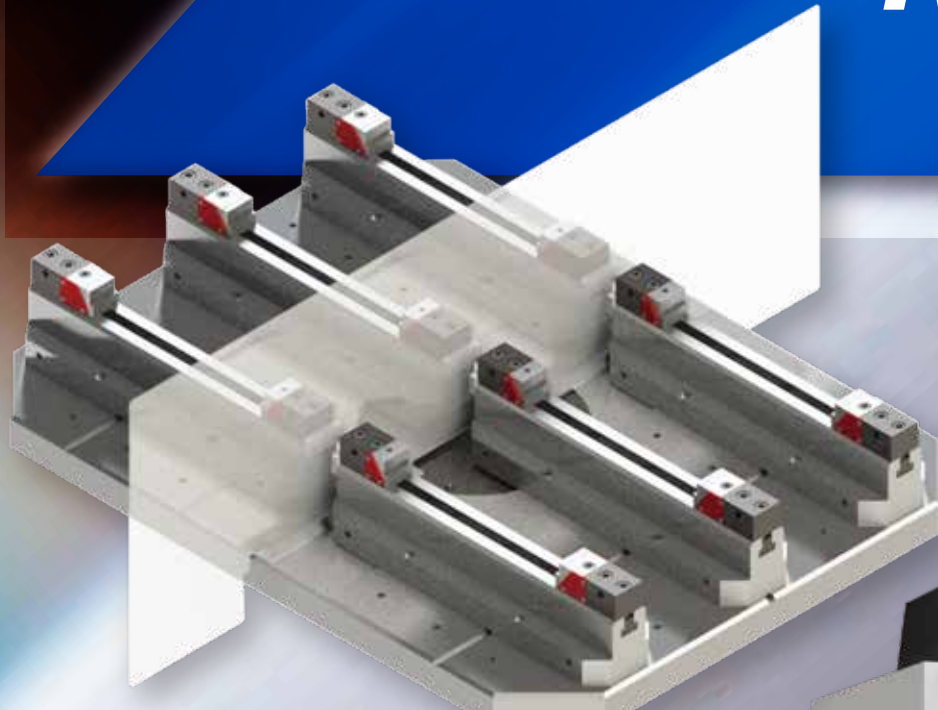

有效利用最大加工领域

机床上安装简易  
和机床没有干涉



联系

DREAM NAVIGATOR  
SINCE 1909  
TSUDAKOMA

津田驹工业株式会社 关联企业

津田驹技术服务株式会社



邮编 921-8529 石川县野野市市粟田5-100

TEL:(076)294-5180, FAX:(076)294-5156

www.tts-tsudakoma.co.jp

# 安装布局

## VCP-50F Clamp System + R650X2

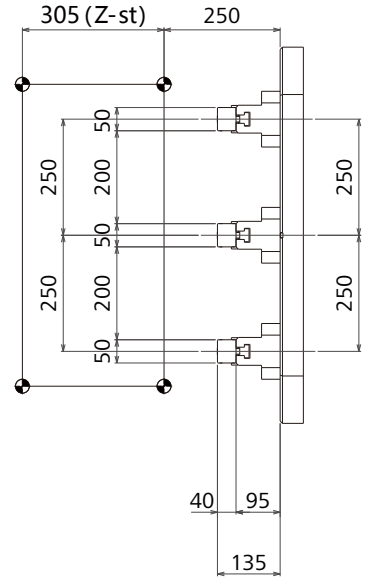
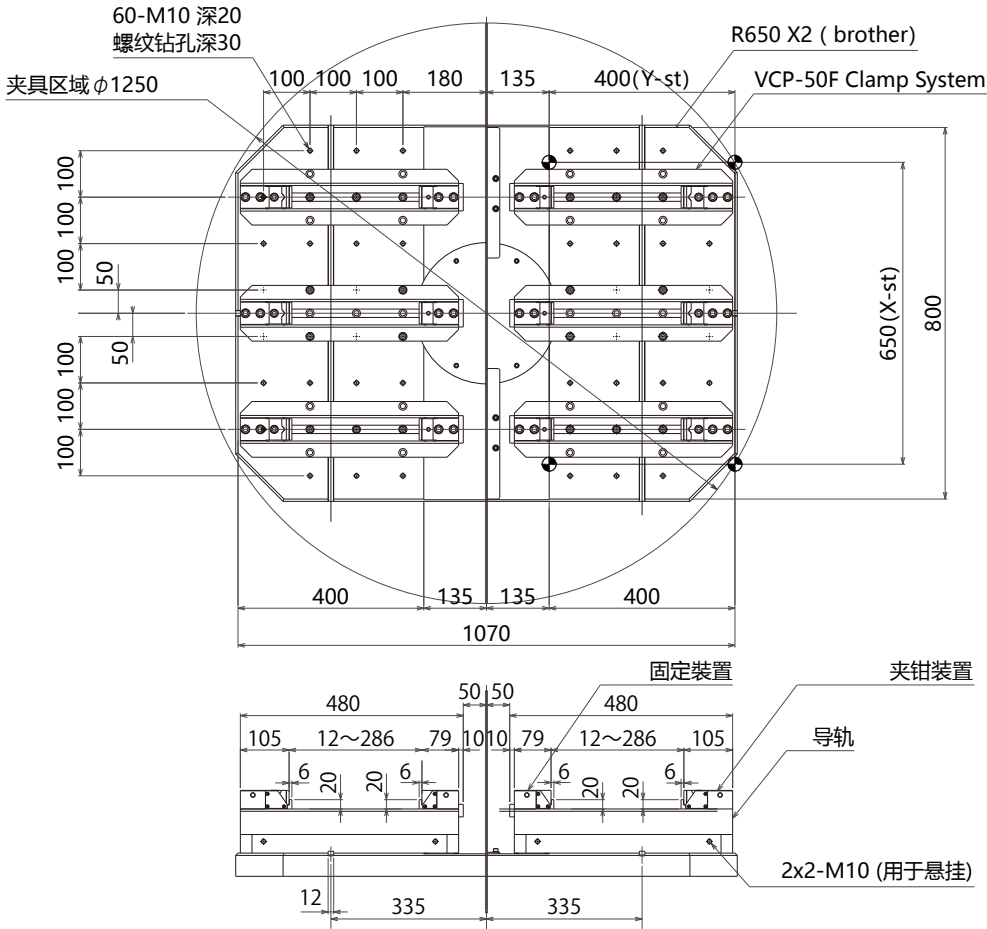

※ R650载重：1面工作台200kg  
 ※ 夹钳装置重量 (含导轨底座)：30kg/set

## VCP-80F Clamp System + R650X2

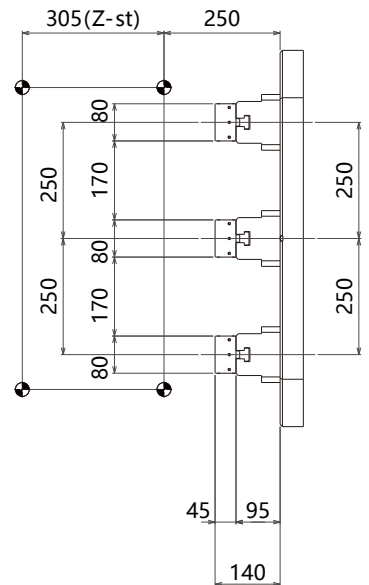
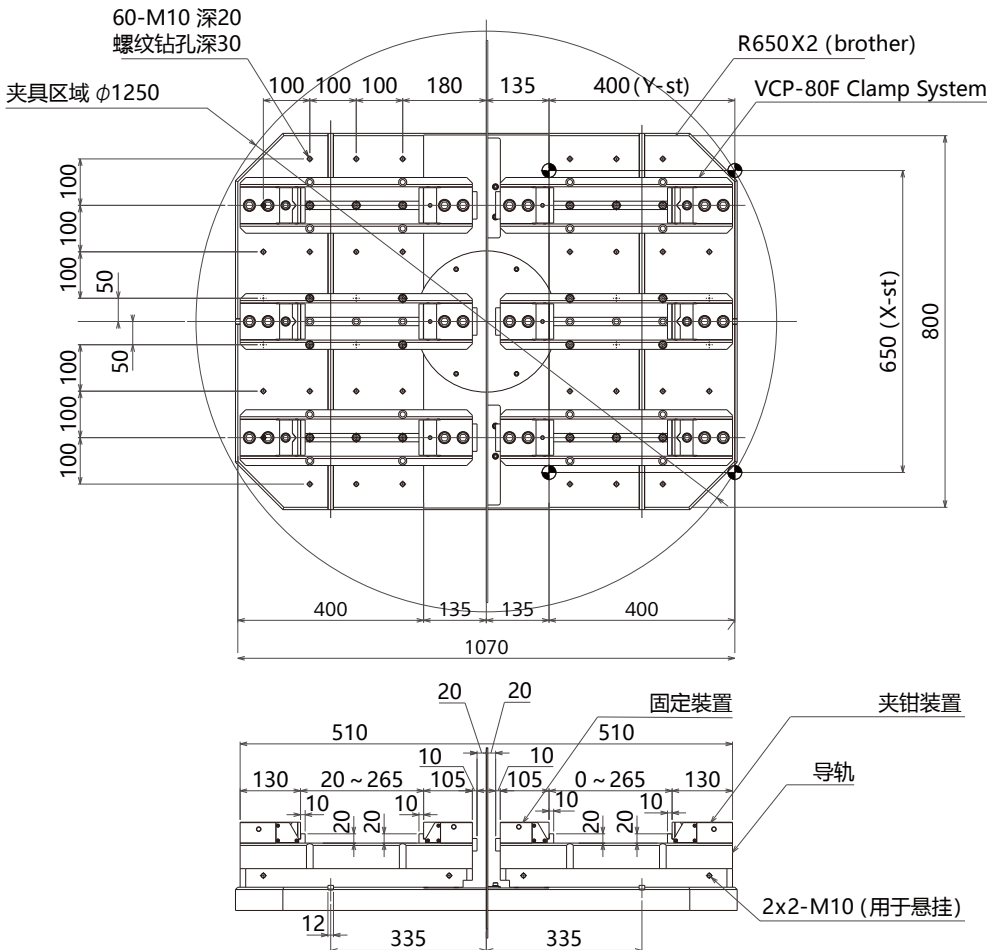

※ R650载重：1面工作台200kg  
 ※ 夹钳装置重量 (含导轨底座)：42kg/set